

Part number:

006-10058

HYDROMA

HYDRAULICKÉ SYSTÉMY

**HIDROMA
SYSTEMS**

UKŁADY HYDRAULICZNE

HYDROMA

ГИДРАВЛИЧЕСКИЕ СИСТЕМЫ

**BILANCIAMENTO, DOPPIO EFFETTO, SERIE "NN"
DUAL PILOT ASSISTED, SERIES "NN" OVERCENTRE**

VBSO-DE-NN

05.42.47 - X - Y - Z

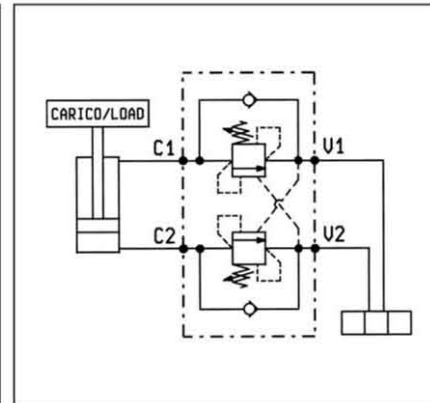
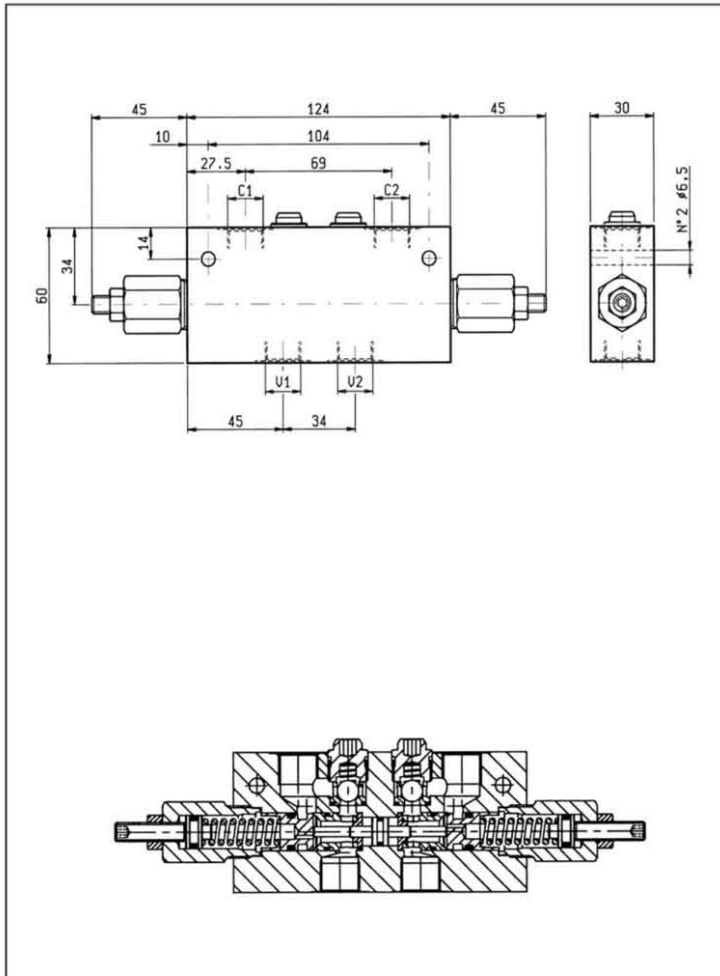

DATI TECNICI / TECHNICAL DATA

Pressione max. 350 bar
Max. pressure

Portata max. 40 l/min
Flow max.

Taratura della valvola: almeno 1.3 volte superiore alla pressione indotta dal carico
Pressure setting: at least 1.3 times the load induced pressure

Peso 0.80 kg
Weight

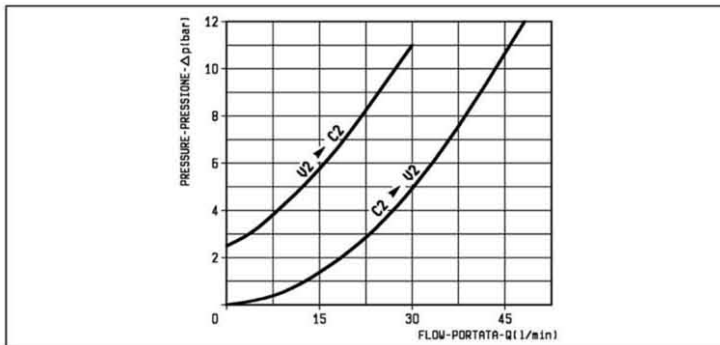

X	RAPPORTO DI PILOTAGGIO PILOT RATIO
03	6.6 : 1
10	2.9 : 1

Z	MOLLE / SPRINGS				
	Campo taratura min - max bar Adj. press. range bar	Incremento press. bar / giro vite Press. increase bar / turn	Taratura standard bar (Q = 5 l/min) Std. setting bar (made at = 5 l/min)	Cod. ordinazione Ordering code	Colore Colour
20	60-210	54	200	03.51.01.102	verde green
35	120-350	118	350	03.51.01.116	giallo yellow

Y	ATTACCHI / PORT SIZE	
	V1-V2-C1-C2	
02	G 3/8	

Marzo 99